



Ride-On MAGNUM A1A Spreader-Sprayer

Operator's Manual



Model # MAGNUM A1A

Proprietary

This document contains data that is proprietary to and controlled by Perma Green Supreme, Inc. The manual may be downloaded as a PDF file and printed for use with Perma Green equipment. Perma Green Supreme, Incorporated reserves the right to control manual content. Therefore, this manual may not be altered in any way without the written permission of Perma Green Supreme, Inc.

Perma Green Supreme, Inc.
Dec/04
Basic Issue

Copyright © 2004, Perma Green Supreme, Inc.

All rights reserved. No part of this book covered by the copyright hereon may be reproduced or copied in any form or by any means, except as permitted by the proprietary data statement for use with Perma Green Supreme equipment, without the written permission of Perma Green Supreme, Inc.



Operator Manual

SAFETY SUMMARY

The processes and procedures provided in this manual may include physical and chemical processes that require the use of pesticides, solvents, chemicals, paints, and other commercially available materials.

The users of this publication must obtain the material safety data sheets [Occupational Safety and Health Act (OSHA) form 20, or equivalent] and product labels from the manufacturers or suppliers of the materials to be used. The users must become completely familiar with the health and safety information, and follow the procedures, recommendations, warnings, and cautions provided by the manufacturer or supplier for the safe use, handling, storage, application, and disposal of toxic or hazardous materials.

WARNING: BEFORE USING ANY OF THE TOXIC OR HAZARDOUS MATERIALS SPECIFIED IN THIS MANUAL, BE AWARE OF ALL HANDLING, STORAGE, AND DISPOSAL INSTRUCTIONS PROVIDED BY THE MANUFACTURER OR SUPPLIER. FAILURE TO FOLLOW THE MANUFACTURER'S OR SUPPLIER'S RECOMMENDATIONS CAN RESULT IN PERSONAL INJURY OR DISEASE.

Refer to the materials list table at the beginning of each section for materials used in the maintenance of this equipment.

WARNINGS provided in this manual are intended to alert operating and maintenance personnel to potential hazards that can result in serious personal injury or disease. These WARNINGS do not replace the manufacturer's or supplier's recommendations.

DANGER notices provided in this manual are intended to alert operating and maintenance personnel to general standards and practices that must be followed to prevent hazardous conditions caused by improper installation and use.

CAUTIONS provided in this manual are intended to alert operators and maintenance personnel to conditions that could result in equipment damage.

This safety advisory contains all the WARNINGS provided in this manual. They are presented in this section to advise you of their existence and to emphasize their importance.

WARNING: READ AND FOLLOW PRODUCT LABEL AND MATERIAL SAFETY DATA SHEET PRECAUTIONS WHEN HANDLING THE MATERIAL YOU ARE POURING INTO THE HOPPER. SOME DUSTS MAY PRESENT HEALTH HAZARDS AND WILL REQUIRE PROTECTIVE CLOTHING AND/OR BREATHING EQUIPMENT.

WARNING: READ AND FOLLOW PRODUCT LABEL AND MATERIAL SAFETY DATA SHEET PRECAUTIONS WHEN HANDLING THE MATERIAL YOU ARE MIXING AND POURING INTO THE SPRAY TANK. SOME MATERIALS MAY PRESENT HEALTH HAZARDS AND WILL REQUIRE PROTECTIVE CLOTHING AND/OR BREATHING EQUIPMENT.



Operator Manual

- WARNING:** READ AND FOLLOW PRODUCT LABEL AND MATERIAL SAFETY DATA SHEET PRECAUTIONS WHEN HANDLING THE MATERIAL YOU ARE POURING INTO THE HOPPER OR MIXING AND POURING INTO THE SPRAY TANK. SOME MATERIALS MAY PRESENT HEALTH HAZARDS AND WILL REQUIRE PROTECTIVE CLOTHING AND/OR BREATHING EQUIPMENT.
- WARNING:** TO AVOID SERIOUS BODILY INJURY AND DAMAGE TO THE TRANSMISSION OR GEAR SHIFT, THE MACHINE MUST BE AT A COMPLETE STOP BEFORE SHIFTING. DO NOT APPLY EXCESSIVE FORCE TO THE GEAR SHIFT. IF THE TRANSMISSION IS DIFICULT TO SHIFT, MOVE THE FRONT WHEELS SLIGHTLY TO FREE UP THE TRANSMISSION UNTIL IT SHIFTS EASILY.
- WARNING:** THE MACHINE HAS A HIGH CENTER OF GRAVITY. WHEN TURNING, ALWAYS LEAN INTO THE TURN. WHEN OPERATING ON A SLOPING SURFACE, ALWAYS LEAN INTO THE SLOPE. OBSERVE THE RIDING RECOMMENDATIONS PROVIDED IN FIGURE 6.
- WARNING:** THE MATERIALS BEING SPREAD BY THIS MACHINE MAY BE TOXIC OR PRESENT HEALTH HAZARDS. REVIEW THE HANDLING, STORAGE, AND DISPOSAL INSTRUCTIONS PROVIDED BY THE MANUFACTURER OR SUPPLIER. FAILURE TO FOLLOW THE MANUFACTURER'S OR SUPPLIER'S RECOMMENDATIONS CAN RESULT IN PERSONAL INJURY OR DISEASE.
- WARNING:** TO PREVENT INJURY, WEAR EYE PROTECTION WHEN USING COMPRESSED AIR TO CLEAN THE HOPPER. REGULATE THE AIR PRESSURE TO 29 PSI (200 KILOPASCALS).
- WARNING:** THE MATERIAL SPREAD FROM THE HOPPER MAY PRESENT A HEALTH HAZARD. FOLLOW THE DISPOSAL INSTRUCTIONS ON THE PRODUCT LABEL AND MATERIAL SAFETY DATA SHEET FOR THE MATERIAL THAT WAS SPREAD. ALSO FOLLOW ANY LOCAL REGULATIONS THAT APPLY TO THE PRODUCT.
- WARNING:** THE MATERIAL USED IN THE SPRAYER MAY PRESENT A HEALTH HAZARD. FOLLOW THE DISPOSAL INSTRUCTIONS ON THE PRODUCT LABEL AND MATERIAL SAFETY DATA SHEET FOR THE MATERIAL THAT WAS SPRAYED. ALSO FOLLOW ANY LOCAL REGULATIONS THAT APPLY TO THE PRODUCT.
- WARNING:** TO AVOID PERSONAL INJURY, PERFORM MACHINE MAINTENANCE WITH THE ENGINE OFF. IF THE ENGINE HAS BEEN OPERATING, MAKE SURE THE ENGINE HAS COOLED BEFORE PERFORMING ANY MAINTENANCE ON THE ENGINE.



Operator Manual

WARNING: INCORRECT SWITCH SETTING CAN RESULT IN UNANTICIPATED AND RAPID MOVEMENT OF THE MACHINE CAUSING DAMAGE TO THE MACHINE OR OTHER PROPERTY AND SEVERE PERSONAL INJURY.

WARNING: TO AVOID SERIOUS BODILY INJURY OR PROPERTY DAMAGE CAUSED BY AN UNANTICIPATED RAPID MOVEMENT OF THE MACHINE, FOLLOW THESE PROCEDURES. BEFORE ATTEMPTING TO START, ALWAYS VERIFY THAT THE TRANSMISSION IS COMPLETELY IN NEUTRAL. DO NOT ATTEMPT TO START IF YOU OR SOMEONE ELSE COULD BE TRAPPED BETWEEN THE MACHINE AND ANY OBSTICAL IF THE MACHINE SHOULD SUDDENLY MOVE. DO NOT OPERATE THE THROTTLE LEVER WHILE STARTING. DO NOT OPERATE THE MACHINE IF THE NEUTRAL SAFETY MECHANISM IS NOT WORKING



Operator Manual

RECORD OF REVISIONS

Keep this record in the front of the manual. When a revision is provided, insert the revised pages in the manual. Record the revision number, the date the revision was inserted in the manual, and provide your initials or signature in the BY column.

REVISION	DATE	BY	DESCRIPTION



Magnum A1A Spreader-Sprayer

Operator Manual

THIS PAGE INTENTIONALLY LEFT BLANK

RECORD OF REVISIONS

Page iv
Dec/04

Refer to the cover page for restrictions regarding reproduction or disclosure of this material.



Operator Manual

LIST OF EFFECTIVE PAGES

<u>Subject</u>	<u>Page</u>	<u>Date</u>	<u>Subject</u>	<u>Page</u>	<u>Date</u>
Title Page	1	Dec/04	Calibration and Adjustment	301	Dec/04
	2	Dec/04		302	Dec/04
				303	Dec/04
Safety Summary	1	Dec/04		304	Dec/04
	2	May/05		305	Dec/04
				306	Dec/04
Record of Revisions	1	Dec/04		307	Dec/04
	2	Dec/04		308	Dec/04
List of Effective Pages	1	Dec/04	Fault Isolation	401	Dec/04
	2	Dec/04		402	Dec/04
				403	Dec/04
Table of Contents	1	Dec/04		404	Dec/04
	2	Dec/04		405	Dec/04
				406	Dec/04
Introduction	1	Dec/04	Maintenance	501	Dec/04
	2	Dec/04		502	Dec/04
Description	101	Dec/04	Warranty	601	Dec/04
	102	Dec/04		602	Dec/04
	103	Dec/04			
	104	Dec/04			
	105	Dec/04			
	106	Dec/04			
	107	Dec/04			
	108	Dec/04			
Operation	201	Dec/04			
	202	Dec/04			
	203	Dec/04			
	204	May/04			
	205	Dec/04			
	206	Apr/05			
	207	Dec/04			
	208	Dec/04			
	209	Dec/04			
	210	Dec/04			
	211	Dec/04			
	212	Dec/04			
	213	Dec/04			
	214	Dec/04			
	215	Dec/04			
216	Dec/04				

LIST OF EFFECTIVE PAGES

Refer to the cover page for restrictions regarding reproduction or disclosure of this material.



Magnum A1A Spreader-Sprayer

Operator Manual

THIS PAGE INTENTIONALLY LEFT BLANK

LIST OF EFFECTIVE PAGES

Page vi
Dec/04

Refer to the cover page for restrictions regarding reproduction or disclosure of this material.



Operator Manual

TABLE OF CONTENTS

<u>Subject</u>	<u>Page</u>
Introduction.....	1
Description.....	101
Operation	201
Calibration and Adjustment	301
Fault Isolation	401
Maintenance.....	501
Warranty	601



Operator Manual

List of Illustrations

<u>Figure No.</u>	<u>Figure Title</u>	<u>Page</u>
Figure 1.	Magnum A1A Spreader-Sprayer	2
Figure 2.	Magnum A1A Component Location	103
Figure 3.	Operator Control Symbols, WARNINGS, and CAUTIONs (five sheets)	104
Figure 4.	Operating Controls Location.....	205
Figure 5.	Spray Control Valve Setting	206
Figure 6.	Riding the Magnum A1A Spreader-Sprayer.....	208
Figure 7.	Spreader Pattern and Distribution Rate.....	209
Figure 8.	Spreader Rate Lever and Open/Close Lever.....	210
Figure 9.	Sprayer Pattern.....	211
Figure 10.	Setting the Sprayer Control Valve	212
Figure 11.	Setting the Spreader Adjustment Holes	302
Figure 12.	Spreader Material Distribution Ratio.....	303

List of Tables

<u>Table No.</u>	<u>Table Title</u>	<u>Page</u>
Table 1.	Engine and Transmission Oil Type, Volume, and Temperature Range	201
Table 2.	Spray Mix Rate	203
Table 3.	Material Distribution Ratio by Percentage	304
Table 4.	Spreader-Sprayer Does Not Start.....	401
Table 5.	Incorrect Spread Pattern.....	402
Table 6.	Spreader Does Not Operate	403
Table 7.	Incorrect Spray Pattern	404
Table 8.	Sprayer Does Not Operate (two sheets).....	405

TABLE OF CONTENTS



Operator Manual

INTRODUCTION

1. General

This Operator's manual provides a physical and mechanical description of the Perma Green Supreme ride-on Magnum A1A spreader-sprayer, and describes its operation.

The manual includes description, operation, inspection, filling information, starting, operating, and stopping information, servicing information, and cleanup information. The operating information includes adjustment procedures, calibration procedures, and operator fault isolation.

This document contains data that is proprietary to and controlled by Perma Green Supreme, Inc. The manual may be downloaded from www.permagreen.com as a PDF file and printed for use with Perma Green Supreme equipment. Perma Green Supreme, Inc., reserves the right to control manual content. Therefore, this manual may not be altered in any way without the written permission of the Perma Green Supreme, Inc.

2. Equipment Description

The Perma Green Magnum A1A (refer to Figure 1) is a four-wheeled vehicle providing two working speeds. It is powered by a Honda engine, and controlled by the operator who stands on a rear-mounted hinged sulky. The operator steers and controls the vehicle using operator controls mounted on the vehicle handlebars. The foot-operated vehicle brakes are mounted on the sulky.

3. Product Support Services

Replacement parts, technical publications, and other product support services are available from Perma Green Supreme, Inc. Please contact:

Perma Green Supreme, Inc.
5609 Murvhill Road
Valpariso, IN 46383-8324
Phone: 800 346 2001
Fax: 219 476 7113
e-mail: support@permagreen.com



Operator Manual



Figure 1. Magnum A1A Spreader-Sprayer

INTRODUCTION



Operator Manual

DESCRIPTION

1. Technical Description

The major functional elements of the Perma Green Magnum A1A are described below (refer to Figure 2).

- The Perma Green Magnum A1A spreader-sprayer is built on a heavy gauge 300 series stainless steel frame. A polyethylene hood protects the undercarriage components from the dust and chemicals from the spreader-sprayer and protects the operator from moving parts.
- The spreader-sprayer operating and drive components are mounted on the front section of the two-section machine. The rear section is a sulky that the operator stands on during operation. The machine is controlled by handlebars mounted to the front section.
- The spreader-sprayer uses a pull-start, 6.5 horsepower Honda Model GX200-HR2 engine that has an integral 1:2 gear reduction transmission with an oil-bath, centrifugal clutch. The heavy duty, hand-operated, centrifugal clutch engages when the engine speed is increased above idle.
- Normal engine idle speed is 1400 + 200/-150 rpm. When the engine is operating at full throttle, the normal engine operating speed is 3450 rpm.
- The transmission provides high and low forward speeds, neutral, and reverse. At an engine speed of 3450 rpm, high gear provides a forward speed of 5 mph (8 km/h). Low gear provides a forward speed of 3.5 mph (5.6 km/h).
- The interface between the engine/gearbox and transaxle is through a horizontal drive shaft and a belt and pulley arrangement.
- The interface between the gearbox and the spreader is through a jackshaft and belt/pulley arrangement to a 1:5 ratio gearbox that results in a speed reduction to approximately 411 rpm at both high speed and low speed operation.
- The spreader is designed and manufactured by Perma Green. The spread pattern and spread rate are adjustable. A remotely-operated deflector limits the spread pattern to the left side only for edging. When using the deflector, a remotely-operated sliding plate closes the third hole to proportionally reduce the product flow and balance the spreader pattern.
- The hopper has been designed and built specifically for the Magnum A1A spreader-sprayer. Its capacity is 150 pounds (68 kilograms) of granulated material. The hopper includes a shower cap that covers the hopper during rain.



Operator Manual

- The sprayer system has a 12-gallon tank (45.4 liters) and uses the same jackshaft and belt/pulley arrangement to drive a pump that provides a nominal spray pressure of 15 ± 3 psi (103 ± 21 kPa). The sprayer uses Turbo Floodjet[®] nozzles that have flow rates matched to the machine travel speed and selected pattern.
- The high gear broadcast nozzle provides a spray pattern 11 feet (3.35 m^2) wide at 90 ± 9 ounces (2.7 ± 0.27 liters) per minute. The high gear trim nozzle provides a spray pattern three feet (0.9 meter) wide, with a proportional reduction of the flow rate.

The low gear broadcast nozzle provides a spray pattern 11 feet (3.35 m^2) wide at 66 ± 7 ounces (2 ± 0.2 liters) per minute. The low gear trim nozzle provides a spray pattern three feet (0.9 meter) wide, with a proportional reduction of the flow rate.

- The front tires are 9.50-8 x 18 knobby tread; the rear tires are 6.50-6 x 12 turf tires. All tires are filled with a mixture of RV antifreeze and water to provide ballast.
- The spreader-sprayer has rear wheel brakes only. The brakes are operated by a foot pedal mounted on the sulky. The brakes only operate when the spreader-sprayer is traveling forward.
- The spreader-sprayer has a multi-function display providing a variety of information. When the engine is OFF, it displays engine run time to the tenth of an hour. When the engine is ON, the display shows engine rpm. When the engine has accumulated 25 hours, the display flashes LUBE, indicating that the engine requires periodic maintenance. The flashing LUBE message will remain on for one hour of engine operation and then turn off regardless of whether the maintenance was performed. The message will reappear after an additional 25 hours of engine operating time.
- The spreader-sprayer includes a hand-carried, squeeze-and-spray bottle for spot spraying areas to 500 ft^2 (46.5 meters^2) that cannot be effectively sprayed by the Magnum sprayer. The spray bottle is carried in a machine-mounted bracket, and includes a fill valve for refilling the bottle from the 12-gallon (45.4 liters) spray tank.
- The spreader-sprayer dimensions are:
 - 55 inches (140 millimeters) long,
 - 35.5 inches (90 millimeters) wide,
 - 41 inches (104 millimeters) high, with the handlebar lowered.

2. Optional Equipment

The optional equipment available from Perma Green for the spreader-sprayer is listed below.

- Hitch-mounted carrying rack, with ramps and tail lights,
- Spare parts kit that includes commonly needed replaceable parts.
- Calibration kit, including collection pans, a collection pitcher, a gauging key, and a graduated cylinder for measurement of the collected product.

DESCRIPTION

Operator Manual

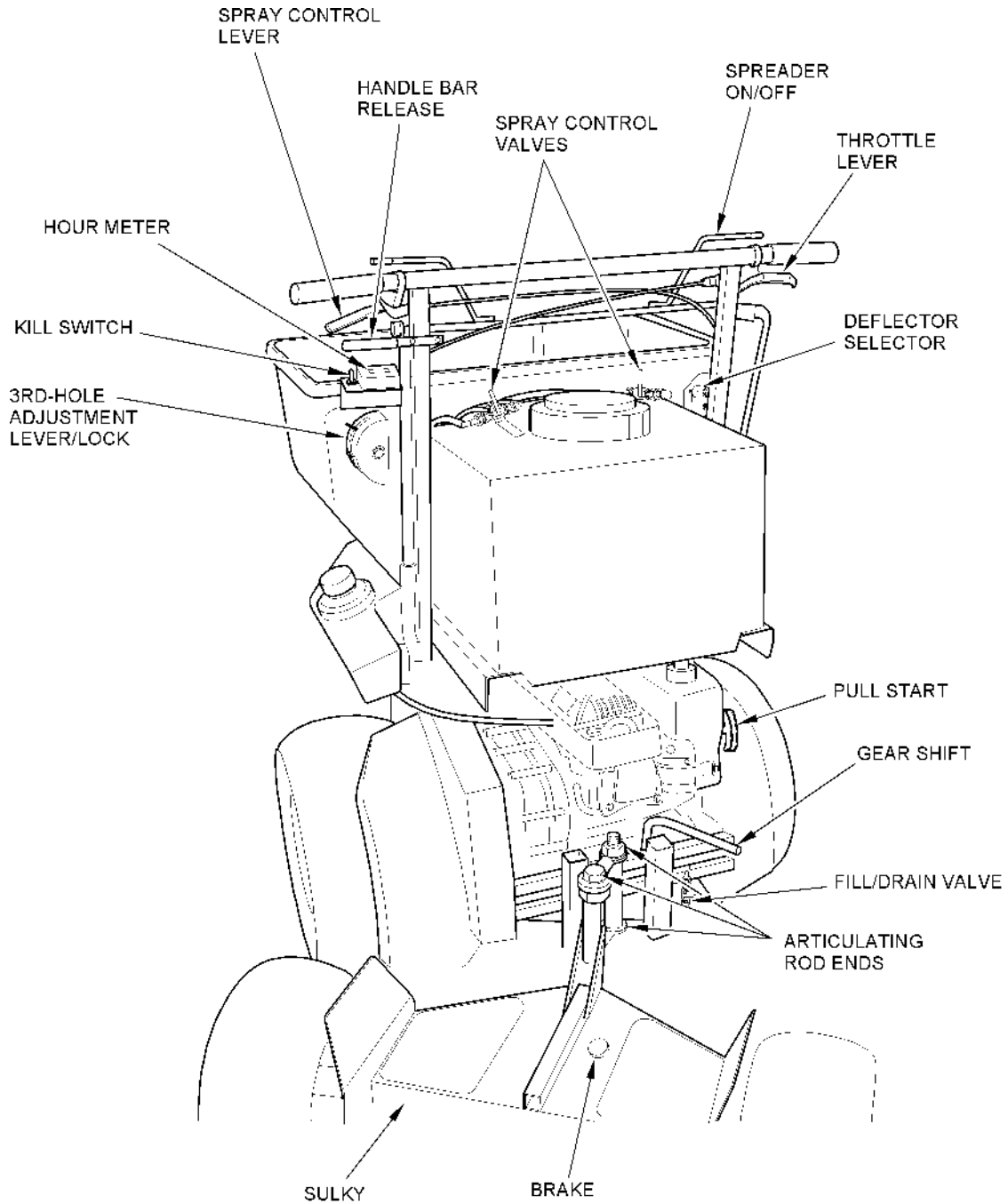

Figure 2. Magnum A1A Component Location

Operator Manual

3. Operator Control Symbols, WARNINGS, and CAUTIONS

The operator control symbols and the machine WARNINGS, and CAUTIONS are shown as they appear on the machine, and are explained in Figure 3.

General Operation WARNING Placard

Located on the top surface of the spray tank, this placard provides the general WARNINGS for safe operation of the spreader-sprayer.

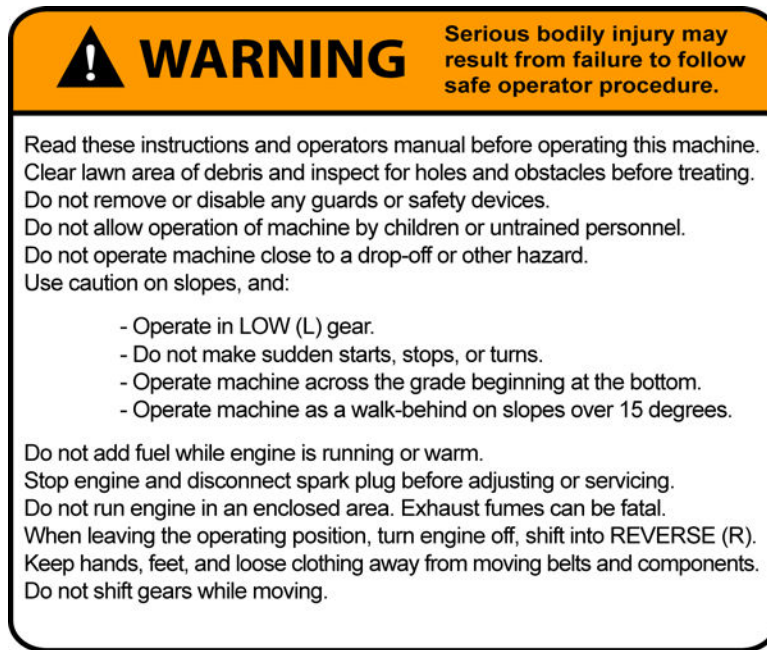

Pulley Pinch Point WARNING Placard

Located next to the pulleys and belts, these placards provides a graphic and written WARNING for keeping the hands clear of the belts and pulleys during operation.

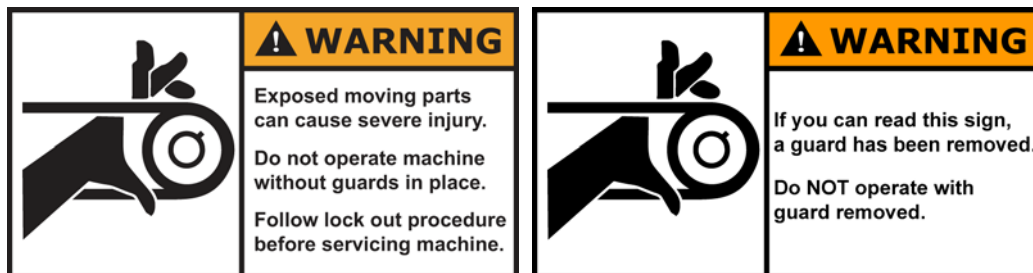

Figure 3. Operator Control Symbols, WARNINGS, and CAUTIONS (sheet 1 of 5)

DESCRIPTION

Operator Manual

Machine Transport CAUTION Placard

Located on the surface of the fuel tank, this placard provides machine handling precautions to prevent flooding the engine with gasoline while transporting the machine or performing maintenance that requires tipping the machine.



Machine Starting Instruction Symbol Placard

Located on the handlebar, this placard provides graphic starting instructions.

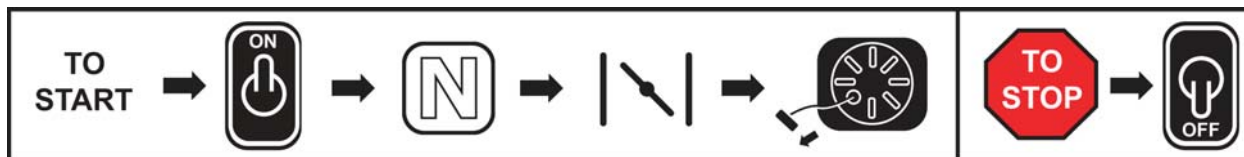

Gearshift Symbol Placard

Located on the frame just beneath the gearshift lever, this placard shows gear locations.



Figure 3. Operator Control Symbols, WARNINGS, and CAUTIONS (sheet 2 of 5)

Operator Manual

Transmission WARNING Placard

Located on the frame just beneath the gearshift label, this placard provides a written WARNING against shifting the transmission gears without first stopping the machine.



Third Hole Adjustment Setting Lever Placard

Located next to the third-hole adjustment lever, this placard provides a graphic representation of the third-hole adjustment settings. In the fully up position, the hole is closed. In the fully down position, the hole is completely open. The hole opening in intermediate positions is proportional to its position.

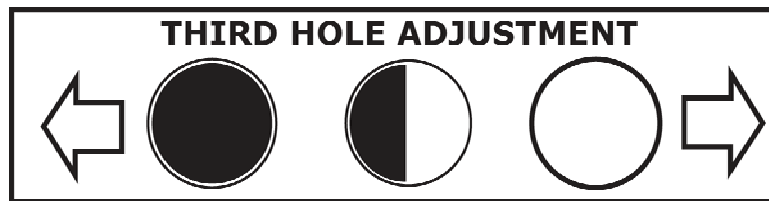

Deflector ON/OFF Placard

Located next to the deflector control, this placard shows the ON and OFF positions for the deflector control lever.



Figure 3. Operator Control Symbols, WARNINGS, and CAUTIONS (sheet 3 of 5)

DESCRIPTION

Operator Manual

Hopper Control and Throttle Placard

Located toward the right side of the handle bar, this placard provides graphic instructions for operating the spreader ON/OFF lever and shows the throttle lever location.

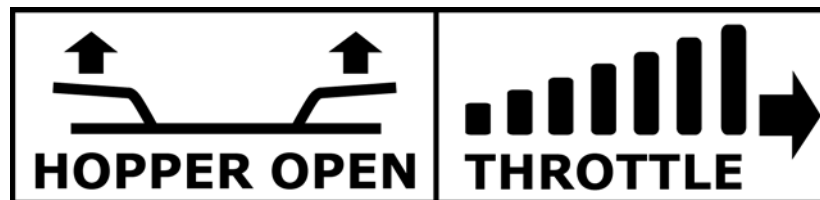

Sprayer Control and Handlebar Drop Placards

Located toward the left side of the handle bar, this placard provides graphic instructions for lowering the handlebar and shows the sprayer control lever location.



Drive Speed Sprayer Setting Placard

Located on the left-hand sprayer selector control panel, on the top surface of the spray tank, this placard shows the lever settings for operating the sprayer at DRIVE speed.

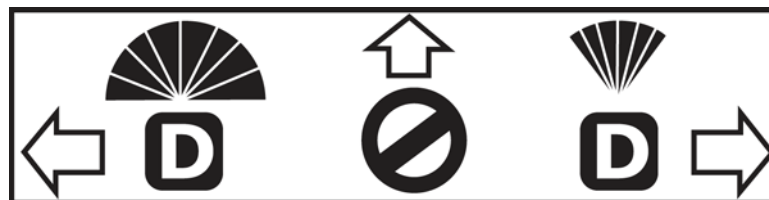

Figure 3. Operator Control Symbols, WARNINGS, and CAUTIONS (sheet 4 of 5)

Operator Manual

Low Speed Sprayer Setting Placard

Located on the right-hand sprayer selector control panel, on the top surface of the spray tank, this placard shows the lever settings for operating the sprayer at LOW speed.

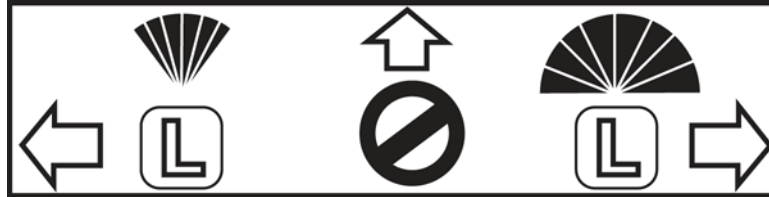

Figure 3. Operator Control Symbols, WARNINGS, and CAUTIONS (sheet 5 of 5)



Operator Manual

OPERATION

1. Pre-Operation Procedures

Before operating the spreader-sprayer perform the inspections, checks, and servicing listed below. Refer to Figure 2 for component location.

- a. Check the machine hour meter. Perform any scheduled maintenance required by the operation time.
- b. Perform the maintenance and inspections in the Daily Maintenance Checklist provided in the Maintenance section. Record all check results in the Daily Maintenance Checklist.
- c. Visually check the machine to make sure all threaded fasteners are present and secure. Tighten any fasteners that are loose and replace fasteners that are missing.
- d. With the spreader-sprayer on a level surface, check the engine oil level. Add oil if necessary. Refer to Table 1 for engine and transmission oil capacity and type.

Temperature Range	Oil Type	Oil Volume-Engine	Oil Volume-Clutch
Summer temperature operation, +50°F (10° C) and higher	SAE 30	0.63 US quart (0.6 liter)	0.53 US quart (0.5 liter)
Summer temperature operation +50°F (10° C) and higher	SAE 10W-30	0.63 US quart (0.6 liter)	0.53 US quart (0.5 liter)
Low temperature operation +30°F to -22°F (0°C to -30°C)	SAE 5W-30	0.63 US quart (0.6 liter)	0.53 US quart (0.5 liter)

Table 1. Engine and Clutch Oil Type, Volume, and Temperature Range

- e. Grease the rear wheel bearings using Mobilux EP 2 grease, or equivalent. Each wheel has a zerk fitting. If a fitting is missing, replace the fitting.
- f. Grease the articulating rod ends between the spreader and sulky using Mobilux EP 2 grease, or equivalent. Each rod end has a zerk fitting. If a fitting is missing, replace the fitting.
- g. Grease each pillow block on the jackshaft located under the hood, using Mobilux EP 2 grease, or equivalent. Each pillow block has a zerk fitting. If a fitting is missing, replace the fitting.



Operator Manual

- h. Check the tires. Each tire is filled with RV antifreeze and water to increase traction and stability. If the tires are low, check for damage to the tire. If the tires are not damaged, add a mixture of RV antifreeze and water to bring the fluid to the correct level. Refer to the Repair Manual for the procedures for repairing a damaged tire and for adding the antifreeze/water mixture.
- i. With the engine off, fill the fuel tank.
- j. If the spreader or sprayer pattern requires adjustment, refer to the procedures in section 3, CALIBRATION AND ADJUSTMENT.
- k. If the spreader or sprayer requires calibration, refer to the procedures in section 3, CALIBRATION AND ADJUSTMENT.

WARNING: READ AND FOLLOW PRODUCT LABEL AND MATERIAL SAFETY DATA SHEET PRECAUTIONS WHEN HANDLING THE MATERIAL YOU ARE POURING INTO THE HOPPER. SOME DUSTS MAY PRESENT HEALTH HAZARDS AND WILL REQUIRE PROTECTIVE CLOTHING AND/OR BREATHING EQUIPMENT.

- l. If the machine is to be used as a spreader, fill the hopper with the material to be spread. Do not overfill the hopper

NOTE: The maximum capacity of the hopper is 150 pounds (68 kilograms).

- m. If necessary to control dust or to protect against rain, install the shower cap on the hopper.

WARNING: READ AND FOLLOW PRODUCT LABEL AND MATERIAL SAFETY DATA SHEET PRECAUTIONS WHEN HANDLING THE MATERIAL YOU ARE MIXING AND POURING INTO THE SPRAY TANK. SOME MATERIALS MAY PRESENT HEALTH HAZARDS AND WILL REQUIRE PROTECTIVE CLOTHING AND/OR BREATHING EQUIPMENT.

- n. If the machine is to be used as a sprayer, fill the spray tank with twelve gallons of spray mixed according to material directions (refer to Table 2).



Operator Manual

143 Foot (44 meters) Travel Time, in seconds	Product Label Rate in Ounces/1000 Ft ² (milliliters/93 meters ²)											Ounces of Product to Mix for One Gallon of Spray (milliliters/liter)
	0.5 (14.8)	0.75 (22.2)	0.8 (23.7)	0.9 (26.6)	1.0 (29.6)	1.1 (32.5)	1.2 (35.5)	1.25 (37.0)	1.3 (38.4)	1.4 (41.4)	1.5 (44.4)	
18	2.37 (18.5)	3.56 (27.8)	3.79 (29.6)	4.27 (33.3)	4.74 (37.0)	5.21 (40.7)	5.69 (44.4)	5.93 (46.3)	6.16 (48.1)	6.64 (51.8)	7.11 (55.5)	
19	2.25 (17.5)	3.37 (26.3)	3.59 (28.0)	4.04 (31.5)	4.49 (35.0)	4.94 (38.5)	5.39 (42.1)	5.61 (43.8)	5.84 (45.6)	6.29 (49.1)	6.74 (52.6)	
20 (Nominal High Gear Time)	2.13 (16.6)	3.20 (25.0)	3.41 (26.6)	3.84 (30.0)	4.27 (33.3)	4.69 (36.6)	5.12 (39.1)	5.33 (41.6)	5.55 (43.3)	5.97 (46.6)	6.40 (49.9)	
21	2.03 (15.8)	3.05 (23.8)	3.25 (25.4)	3.66 (28.5)	4.06 (31.7)	4.47 (34.9)	4.88 (38.1)	5.08 (39.6)	5.28 (41.2)	5.69 (44.4)	6.10 (47.6)	
22	1.94 (15.1)	2.91 (22.7)	3.10 (24.2)	3.49 (27.20)	3.88 (30.3)	4.27 (33.3)	4.65 (36.1)	4.85 (37.8)	5.04 (39.3)	5.43 (42.4)	5.82 (45.2)	
23	1.86 (14.5)	2.78 (21.7)	2.97 (23.2)	3.34 (26.1)	3.71 (28.9)	4.08 (31.8)	4.45 (34.7)	4.64 (36.2)	4.82 (37.6)	5.19 (40.5)	5.57 (43.5)	
24	1.78 (14.0)	2.67 (20.8)	2.84 (22.2)	3.20 (25.0)	3.56 (27.8)	3.91 (30.5)	4.27 (33.1)	4.44 (34.6)	4.62 (36.0)	4.98 (38.9)	5.33 (41.6)	
25	1.71 (13.4)	2.56 (20.0)	2.73 (21.3)	3.07 (24.0)	3.41 (26.6)	3.75 (29.3)	4.10 (32.0)	4.27 (33.3)	4.44 (34.6)	4.78 (37.3)	5.12 (39.9)	

Table 2. Spray Mix Rate



Operator Manual

2. Pre-Operation Site Inspection

Before operating the spreader-sprayer, inspect the area that will be covered for operating hazards.

- a. Check the area for hidden debris that could damage the spreader-sprayer.
- b. Check the area for hidden holes, ruts, and natural hazards such as raised tree roots.
- c. Check the area for hidden sprinkler heads and spray equipment.
- d. If necessary, lay out the spreading/spraying lanes using flags to designate turning points.

3. Starting

- a. Open the two fuel shutoff valves. One valve is located on the bottom side of the fuel tank, and the second is located on the back of the engine. Turning the shutoff valves fully counterclockwise opens the shutoff valve.
- b. Set the kill switch to the ON (up) position.
- c. Place the shift lever in the NEUTRAL position.

WARNING: TO AVOID SERIOUS BODILY INJURY OR PROPERTY DAMAGE CAUSED BY AN UNANTICIPATED RAPID MOVEMENT OF THE MACHINE, FOLLOW THESE PROCEDURES. BEFORE ATTEMPTING TO START, ALWAYS VERIFY THAT THE TRANSMISSION IS COMPLETELY IN NEUTRAL. DO NOT ATTEMPT TO START IF YOU OR SOMEONE ELSE COULD BE TRAPPED BETWEEN THE MACHINE AND ANY OBSTACLE IF THE MACHINE SHOULD SUDDENLY MOVE. DO NOT OPERATE THE THROTTLE LEVER WHILE STARTING. DO NOT OPERATE THE MACHINE IF THE NEUTRAL SAFETY MECHANISM IS NOT WORKING.

- d. If necessary, move the choke lever to CHOKE while starting the engine. DO NOT operate the throttle lever while starting.
- e. Pull the starter cord to start the engine. After the engine starts, place the choke in the RUN position.

4. Machine Operation

Refer to Figure 4 for operating controls location.

Operator Manual

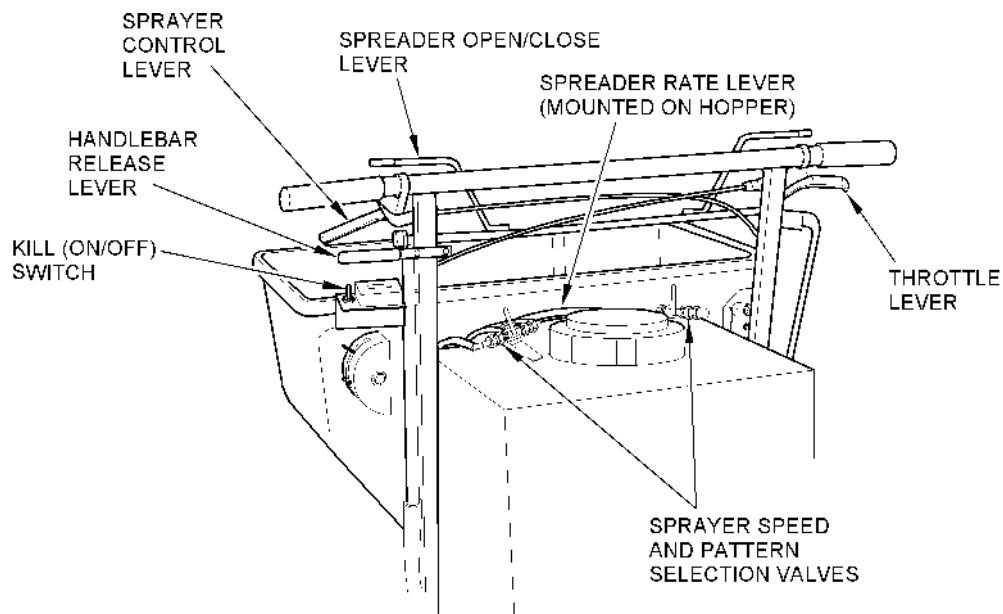

Figure 4. Operating Controls Location

WARNING: READ AND FOLLOW PRODUCT LABEL AND MATERIAL SAFETY DATA SHEET PRECAUTIONS WHEN HANDLING THE MATERIAL YOU ARE POURING INTO THE HOPPER OR MIXING AND POURING INTO THE SPRAY TANK. SOME MATERIALS MAY PRESENT HEALTH HAZARDS AND WILL REQUIRE PROTECTIVE CLOTHING AND/OR BREATHING EQUIPMENT.

- a. If the spreader-sprayer is to be used for spreading, set the rate lever for the material to be spread to the previously calibrated setting for the gear you intend to use.
- b. If the spreader-sprayer is to be used for broadcast spraying, set only the lever on the left-hand spray control valve toward the outside (refer to Figure 5) for spraying in DRIVE. Set only the lever on the right-hand spray control valve to the outside for spraying in LOW.
- c. If the spreader-sprayer is to be used for trim spraying, set only the lever on the left-hand spray control valve toward the inside (refer to Figure 5) for spraying in HIGH. Set only the lever on the right-hand spray control valve to the inside for spraying in LOW.
- d. To shut off the sprayer, release the spray control lever and set the levers on the left-hand and right-hand spray control valves to the center (up) position.
- e. With the throttle lever released, shift the transmission to the desired gear.

NOTE: Operate the spreader-sprayer in DRIVE on relatively level ground. If the ground has a significant slope, operate the spreader-sprayer in LOW.

Operator Manual

- f. Step onto the sulky and grasp the handlebars.
- g. Pull the throttle lever to the fully open (3450 rpm) position against the handlebar. This will engage the centrifugal clutch, causing the spreader-sprayer to move.
- h. To turn the spreader-sprayer, turn the handlebars in the direction of the turn. Shift your body weight to the side of the direction of the turn.
- i. To shift from DRIVE to LOW or LOW to DRIVE, first stop the machine by releasing the throttle lever and stepping on the brake. When the machine has stopped completely, shift to the desired gear. Do not apply excessive force to the gear shift. If it is difficult to shift, move the front wheels slightly to free up the transmission until it shifts easily.

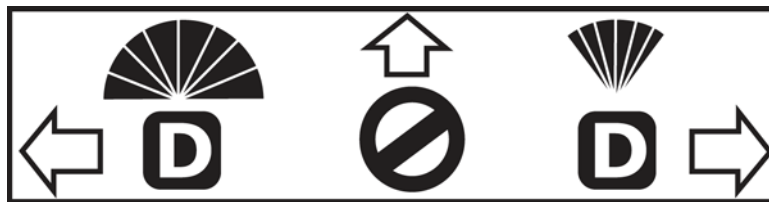

Left-Hand Spray Control is for Operating in Drive

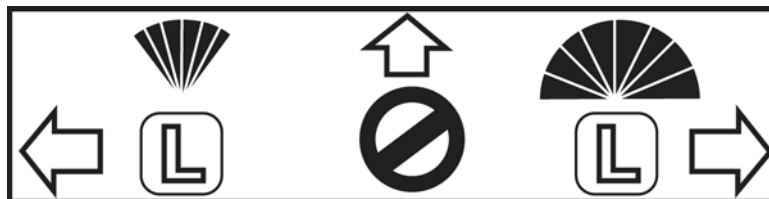

Right-Hand Spray Control is for Operating in Low

Figure 5. Spray Control Valve Setting

WARNING: TO AVOID SERIOUS BODILY INJURY AND DAMAGE TO THE TRANSMISSION OR GEAR SHIFT, THE MACHINE MUST BE AT A COMPLETE STOP BEFORE SHIFTING. DO NOT APPLY EXCESSIVE FORCE TO THE GEAR SHIFT. IF THE TRANSMISSION IS DIFICULT TO SHIFT, MOVE THE FRONT WHEELS SLIGHTLY TO FREE UP THE TRANSMISSION UNTIL IT SHIFTS EASILY.

- j. To shift from a forward gear to REVERSE or from REVERSE to a forward gear, first stop the machine by releasing the throttle lever and stepping on the brake. When the machine has stopped completely, shift to the desired gear. Do not apply excessive force to the gear shift. If it is difficult to shift, move the front wheels slightly to free up the transmission until it shifts easily.

OPERATION



Operator Manual

WARNING: THE MACHINE HAS A HIGH CENTER OF GRAVITY. WHEN TURNING, ALWAYS LEAN INTO THE TURN. WHEN OPERATING ON A SLOPING SURFACE, ALWAYS LEAN INTO THE SLOPE. OBSERVE THE RIDING RECOMMENDATIONS PROVIDED IN FIGURE 6.

- k. Operate the machine on ground that has a significant slope only in LOW, according to the following instructions (refer to Figure 6).
 - (1) When you turn the machine, point the handlebar in the direction of the turn. Lean into the turn (toward the inside of the turn).
 - (2) To climb a slope, shift to LOW. If you are spraying, set the sprayer to the LOW nozzles. If you are spreading, change the settings to LOW speed spreader operation. Lean into the slope (uphill).
 - (3) To descend a slope, shift to LOW. If you are spraying, set the sprayer to the LOW nozzles. If you are spreading, change the settings to LOW speed spreader operation. Lean into the slope (uphill).
 - (4) To traverse a slope, shift to LOW. If you are spraying, set the sprayer to the LOW nozzles. If you are spreading, change the settings to LOW speed spreader operation. Lean into the slope (uphill).
 - (5) To climb, descend, or traverse slopes that are 15 degrees or greater, stop the machine, shift to LOW, step off the sulky, and release and lower the handlebar. Travel the slope walking behind the machine.

Operator Manual

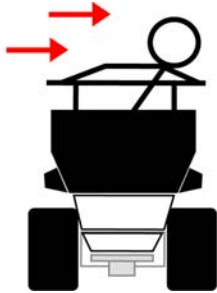

When you turn the machine, point the front of the machine in the direction of the turn. Shift your body weight toward the inside of the turn.

When you go up a slope, first stop and shift the machine into LOW (L) gear. Lean forward, into the slope as you drive up the slope.



When you go down a slope, first stop and shift the machine into LOW (L) gear. Lean to the rear, into the slope as you drive down the slope.

When you are driving the machine across a slope, first stop and shift the machine into LOW (L) gear. Lean into the hill as you travel across the slope.

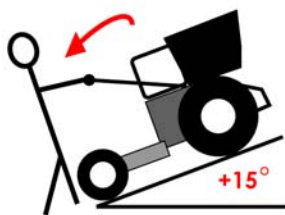
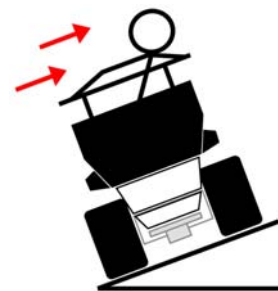

If you have to go up, down, or across steep slopes (15 degrees, or steeper), stop and shift the machine into LOW (L) gear. Release and lower the handlebar. Walk behind the machine as you travel the slope.

When you reach level ground, return the handlebar to the upright position. Make sure the handlebar locks.

Figure 6. Riding the Magnum A1A Spreader-Sprayer

Operator Manual

- (6) After completing travel or spreading/spraying on the slope, raise the handlebar to the upright position, making sure it locks in place. Operate the spreader-sprayer in either DRIVE or LOW, as desired.
 - i. To stop machine operation, release the throttle lever and step on the brake to bring the machine to a stop. Set the shift lever to REVERSE and place the kill switch to OFF. Close the fuel shutoff valve by turning it counterclockwise.

5. Spreader Operation

The spreader has a pattern width of 14 ± 1 feet (4.3 ± 0.3 meters), as shown in Figure 7. Using a 7 ± 1 foot (2.1 ± 0.3 meters) overlap travel pattern provides an even distribution of the product, and using the edge deflector provides an even finished distribution on the surface being treated. The sprayer can be operated at the same time the spreader is in use, and the seven-foot overlap pattern is also effective for the sprayer.

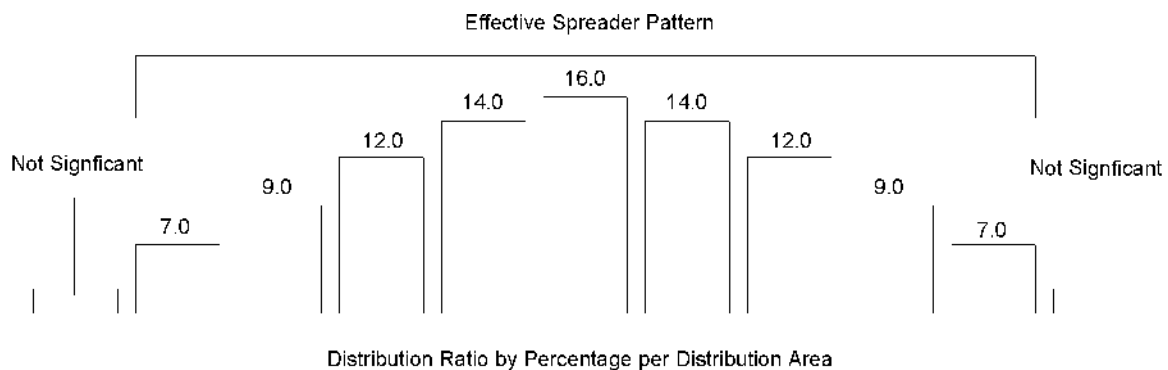

Figure 7. Spreader Pattern and Distribution Rate

- a. Place the rate control arm in the numbered setting determined during calibration for the product to be spread (refer to Figure 8). Select the setting that corresponds to the operating speed you will use (either DRIVE gear or low gear).
- b. Place the gearshift lever in the gear you will use for spreading. Pull the throttle lever to the full operating speed of 3450 rpm.
- c. Start spreader operation by placing the operating lever in the OPEN position.
- d. To stop spreader operation, place the operating lever in the CLOSED position.

Operator Manual

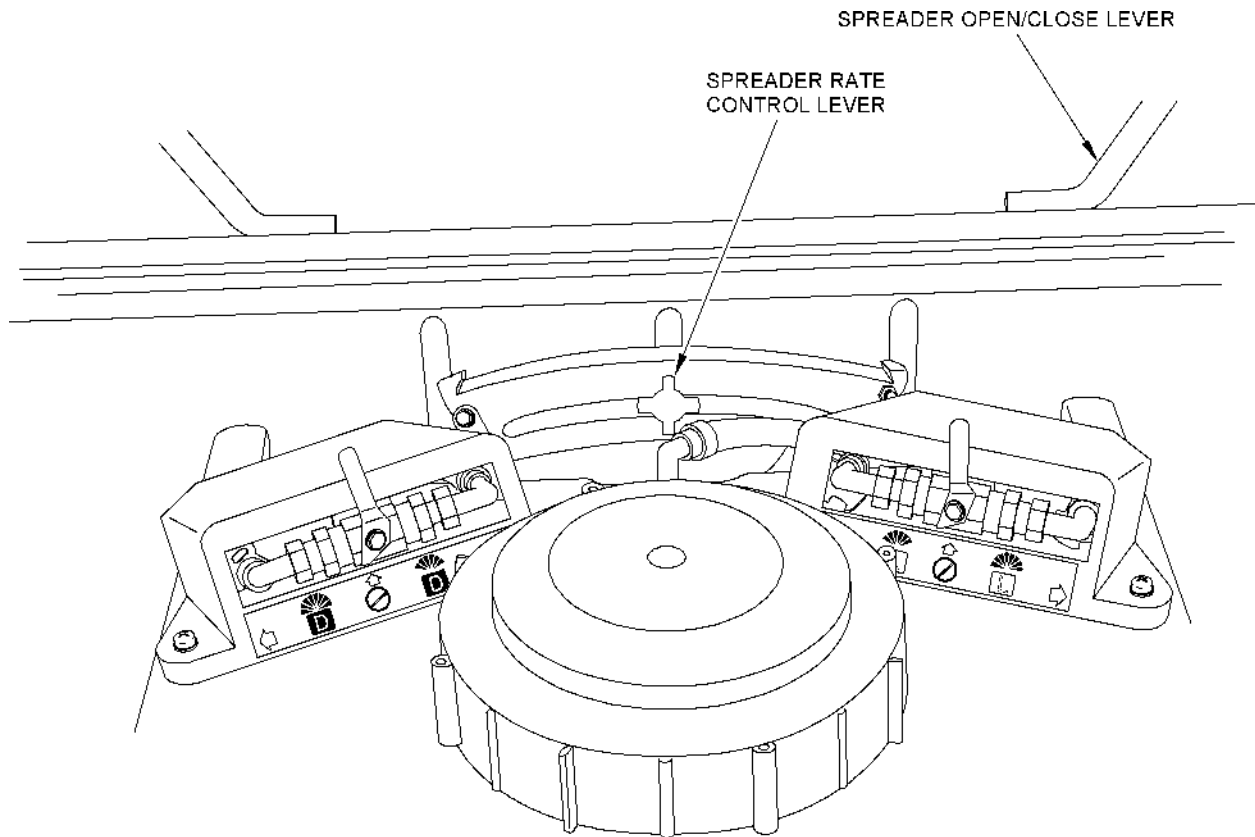

Figure 8. Spreader Rate Lever and Open/Close Lever

6. Sprayer Operation

The sprayer has a pattern width of 11 feet (3.4 meters), as shown in Figure 9. The spray distribution pattern allows the use of the seven-foot (2.1 meters) overlap spreader travel pattern to achieve an even distribution of the sprayed product. Using the edging nozzle provides an even finished distribution on the surface being treated. The sprayer and spreader can be operated at the same time and provide even distribution of both the sprayed and spread products.

Operator Manual

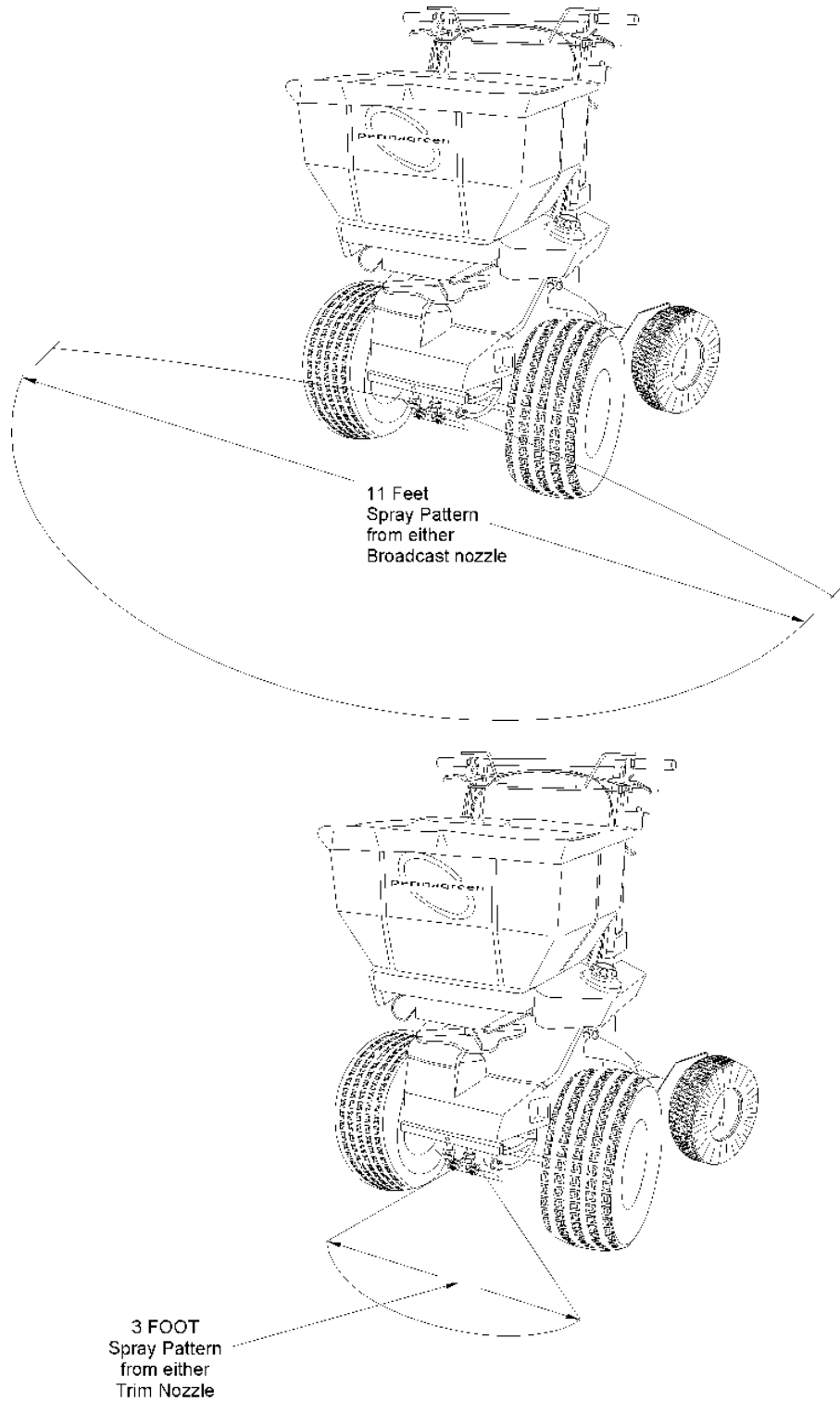

Figure 9. Sprayer Pattern

Operator Manual

WARNING: READ AND FOLLOW PRODUCT LABEL AND MATERIAL SAFETY DATA SHEET PRECAUTIONS WHEN YOU ARE APPLYING THE SPRAY MATERIAL. SOME MATERIALS MAY PRESENT HEALTH HAZARDS THAT WILL REQUIRE PROTECTIVE CLOTHING AND/OR BREATHING EQUIPMENT.

WARNING: TO AVOID PERSONAL CONTAMINATION, APPLY THE SPRAY THE SPRAY DOWNWIND.

- a. Plan the spray application pattern required to cover the manual application area. The spray application pattern must apply the spray downwind. Avoid spraying in windy conditions to avoid drift onto non-targeted areas.
- b. For spraying, set the spray valve (refer to Figure 10) to select the spray nozzle that will be used according to pattern (broadcast or trim) that is desired, and the speed (DRIVE gear or LOW gear) that will be used during spraying.

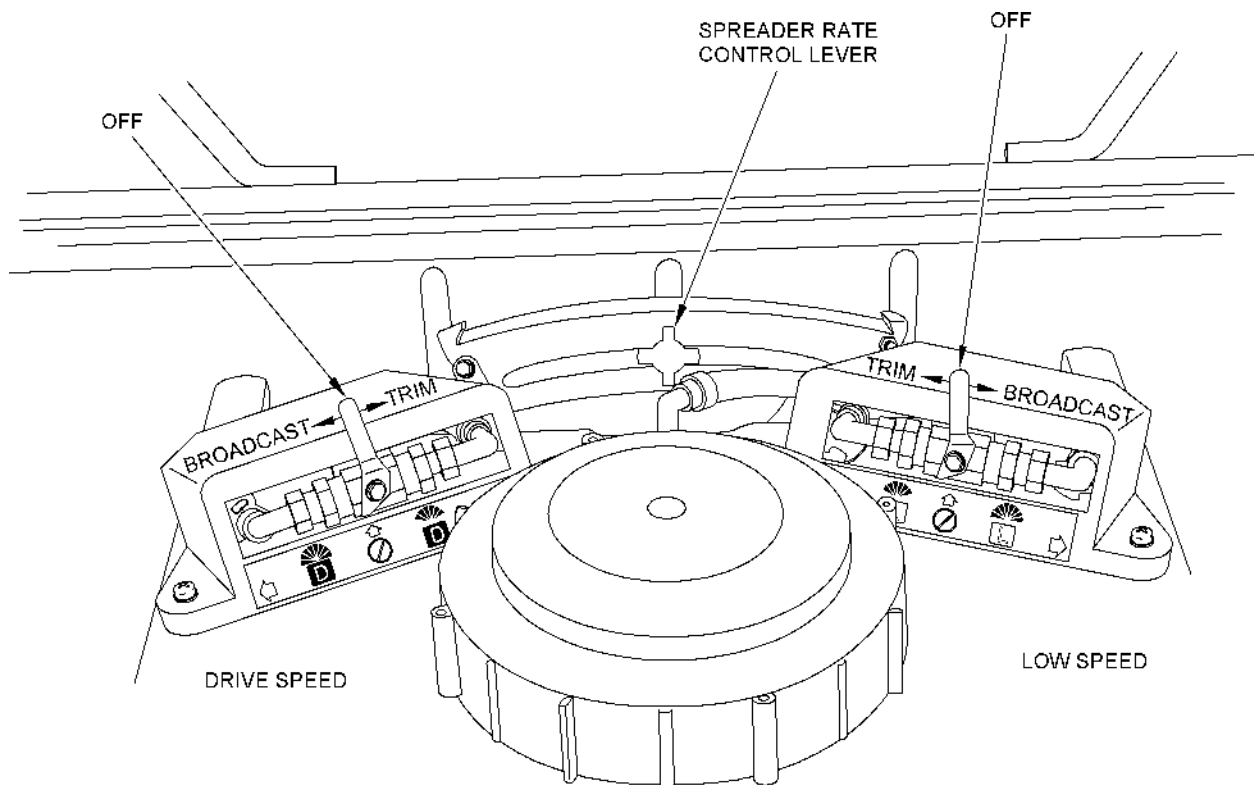

Figure 10. Setting the Spray Control Valve

- c. Place the gearshift lever in the gear you will use for spraying. Pull the throttle lever to full operating speed of 3450 rpm.

OPERATION



Operator Manual

- d. To start momentary sprayer operation, pull the spray lever toward the handgrip. Release the lever to stop spraying.
- e. To start continuous sprayer operation, pull and hold the spray lever toward the handgrip. To stop sprayer operation, release the spray lever.

7. Squeeze and Spray Bottle Operation

The spreader-sprayer includes a hand-carried and hand-operated bottle used to apply spray in areas that the spreader-sprayer cannot reach. When not in use, the spray bottle is carried in a machine-mounted bracket. The bottle includes a fill valve for refilling the bottle from the 12-gallon spray tank and holds enough spray to cover approximately 500 ft² (46.5 meters²).

a. Filling the Spray Bottle

WARNING: READ AND FOLLOW PRODUCT LABEL AND MATERIAL SAFETY DATA SHEET PRECAUTIONS WHEN HANDLING THE MATERIAL YOU ARE MIXING AND POURING INTO THE SPRAY BOTTLE. SOME MATERIALS MAY PRESENT HEALTH HAZARDS THAT WILL REQUIRE PROTECTIVE CLOTHING AND/OR BREATHING EQUIPMENT.

- (1) If the spreader-sprayer is being used to spray the accessible turf areas, the spray bottle can be filled directly from the 12-gallon spray tank using the fill valve.
- (2) If the spreader-sprayer is not in use, use the spray mix rate table to prepare the amount of spray you will need for the area you will be covering. Remove the sprayer cap and pour the spray into the spray bottle.
- (3) Install the spray bottle cap.

b. Applying the Spray

WARNING: READ AND FOLLOW PRODUCT LABEL AND MATERIAL SAFETY DATA SHEET PRECAUTIONS WHEN YOU ARE APPLYING THE SPRAY MATERIAL. SOME MATERIALS MAY PRESENT HEALTH HAZARDS THAT WILL REQUIRE PROTECTIVE CLOTHING AND/OR BREATHING EQUIPMENT.

WARNING: TO AVOID PERSONAL CONTAMINATION, APPLY THE SPRAY DOWNWIND.

- (1) Plan the spray application pattern required to cover the manual application area. The spray application pattern must apply the spray downwind. Avoid spraying in windy conditions to avoid drift onto non-targeted areas.
- (2) Invert the spray bottle. Squeeze the bottle with enough pressure to create the spray pattern needed. Do not walk through the sprayed mist.



Operator Manual

c. Cleanup After Use

WARNING: THE MATERIAL USED IN THE SPRAYER MAY PRESENT A HEALTH HAZARD. FOLLOW THE DISPOSAL INSTRUCTIONS ON THE PRODUCT LABEL AND MATERIAL SAFETY DATA SHEET FOR THE MATERIAL THAT WAS SPRAYED. ALSO FOLLOW ANY LOCAL REGULATIONS THAT APPLY TO THE PRODUCT.

- (1) Remove the spray bottle cap and spray components. Rinse the bottle, cap, and spray components in water.
- (2) Inspect the components for wear and damage before reassembly. Replace damaged and worn components.
- (3) Dispose of spray and cleanup water according to the product label and material safety data sheet.

8. Post-Operation

a. After operation, clean up the spreader-sprayer as follows:

WARNING: TO PREVENT INJURY, WEAR EYE PROTECTION WHEN USING COMPRESSED AIR TO CLEAN THE HOPPER. REGULATE THE AIR PRESSURE TO 29 PSI (200 KILOPASCALS).

WARNING: THE MATERIAL SPREAD FROM THE HOPPER MAY PRESENT A HEALTH HAZARD. FOLLOW THE DISPOSAL INSTRUCTIONS ON THE PRODUCT LABEL AND MATERIAL SAFETY DATA SHEET FOR THE MATERIAL THAT WAS SPREAD. ALSO FOLLOW ANY LOCAL REGULATIONS THAT APPLY TO THE PRODUCT.

- (1) If the machine was used to spread fertilizer from the hopper, empty the hopper of leftover granular material. Use compressed air to blow the residue from the hopper.
- (2) Clean accumulated dust and dirt from the engine and from the muffler area using a stiff-bristled brush.

WARNING: THE MATERIAL USED IN THE SPRAYER MAY PRESENT A HEALTH HAZARD. FOLLOW THE DISPOSAL INSTRUCTIONS ON THE PRODUCT LABEL AND MATERIAL SAFETY DATA SHEET FOR THE MATERIAL THAT WAS SPRAYED. ALSO FOLLOW ANY LOCAL REGULATIONS THAT APPLY TO THE PRODUCT.

- (3) If the sprayer was used, rinse the sprayer tank with approximately five gallons of fresh water and pump the water through the nozzles used for spraying. If material that was sprayed has disposal requirements, catch the water as it is discharged and dispose of it according to the product label and material safety data sheet instructions.



Operator Manual

- (4) Using low-pressure water, flush the machine exterior according to the schedule in Section 5, MAINTENANCE.
 - (5) After flushing the machine exterior, use low-pressure shop air to dry the machine surface and areas that collect water.
- b. After operation, service the spreader-sprayer as follows:
- (1) Visually check the spreader-sprayer for any damage that may have occurred during operation.
 - (2) If the machine was flushed down with water, spray the moving parts except for the drive belt and drive pulleys with a light coat of WD-40, or equivalent.



THIS PAGE INTENTIONALLY LEFT BLANK



Operator Manual

CALIBRATION AND ADJUSTMENT

The spreader-sprayer requires periodic calibration and adjustment to verify the spreader and sprayer patterns and to verify the correct product delivery rates.

1. Spreader Adjustment and Calibration

Adjustment of the spreader establishes the correct spread pattern. The center discharge hole establishes the center of the pattern. The right-hand discharge hole establishes the spread pattern on the left-hand side. The left-hand (third-hole with slide plate) discharge hole establishes the discharge pattern on the right-hand side. Calibration establishes the correct application rate and balances the spreader pattern.

If you did not purchase a calibration kit with your Magnum, obtain the following materials:

- Eleven collection pans, 3 to 4 inches (8 to 10 centimeters) high and about 1 foot (0.3 meter) square (i.e., aluminum roasting pans)
 - Clear tube, 1/2-inch (13 millimeter) internal diameter, 3 to 4 inches (8 to 10 centimeters) tall (to act as a graduated cylinder for measuring the collected fertilizer pellets). Use a thin-tipped permanent marker to mark the tube at quarter-inch (6 millimeter) increments all the way up the tube.
 - Clear, graduated one quart (one liter) measuring cup.
 - Stop watch or wristwatch.
 - This owner's manual, and a pencil to record your collection amounts.
- a. Place the spreader operating lever in the CLOSED position. Verify that the spreader discharge holes are closed.
 - b. If the spreader discharge holes are not completely closed, adjust the length of the connecting rod running from the controls on the right handlebar down the handle to the outer control rod lever by loosening and repositioning the locknuts.
 - c. Establish the spreader initial adjustment and calibration position as follows:
 - (1) Loosen the rate adjustment knob at the rear of the hopper. Insert the #13 position on the calibration gauge into the center adjustment hole, oriented as shown in Figure 11. Pull the spreader operating lever back until the shutoff plate touches the gauge.

Operator Manual

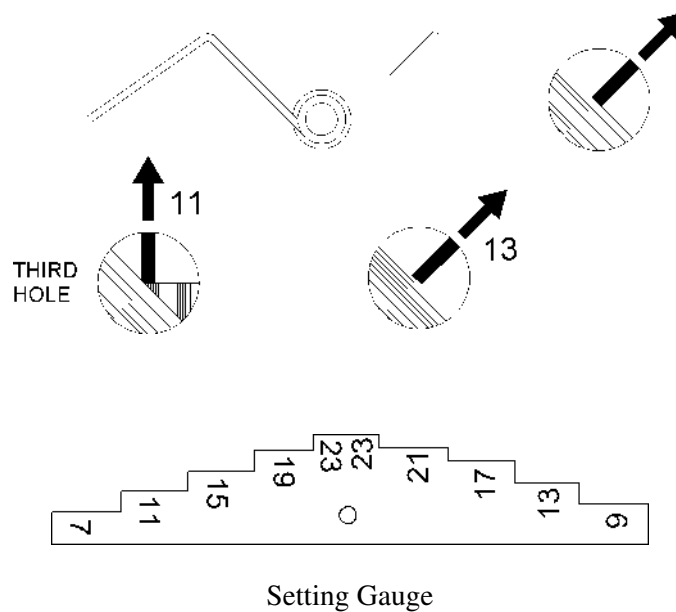

Figure 11. Setting the Spreader Adjustment Holes

- (2) Adjust the rate control arm in the rate control bracket to touch the shutoff plate stop. Tighten the rate adjustment knob. Remove the gauge.
- (3) Place the spreader operating lever at the CLOSED position, then, return it to the OPEN position. Verify the gauge fits snugly in the hole at the #13 gauge position. Repeat the setting process, if necessary.
- (4) Without changing the rate control arm setting, place the operating lever at the OPEN position. Insert the #11 position on the gauge, oriented as shown in Figure 11, in the third-hole right side pattern adjustment hole (left-hand hole). Move the third-hole remote adjustment lever (left-hand side of the hopper) so that the slide plate just contacts the gauge. Move the memory lock (grey sliding piece) until it pops into the lever and locks its position. Remove the gauge.
- (5) Place the third-hole remote adjustment lever at the OFF position, then, return it to the memory lock position. Verify the gauge fits snugly in the hole in the #11 gauge position. Repeat the setting process, if necessary.

Operator Manual

- (6) Check the distribution pattern.
 - (a) Place 11 calibration pans in a line on two-foot centers on a paved area such as a parking lot (refer to Figure 12).

NOTE: Checking and adjusting the distribution pattern requires multiple passes over the calibration pans. This process is done on a paved area to avoid burning the vegetation by over-fertilizing, and to allow the product to be collected and reused.

- (b) With the material to be spread loaded in the spreader, make at least three passes from the same direction over the pans in a path perpendicular to the line of pans while spreading material.

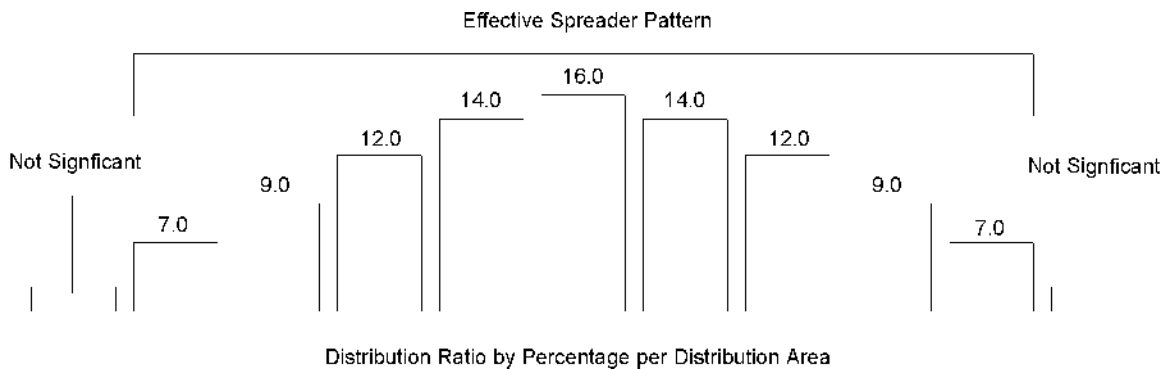

Figure 12. Spreader Material Distribution Ratio

- (c) Pour the contents of the first pan on your far left into the graduated cylinder or clear tube. Measure and record the material deposited (refer to Table 3). Dump the collected pellets back into the bag or hopper. Repeat this measurement for each pan, one by one, until all eleven pans are emptied and recorded.
- (d) Add together all eleven recorded numbers to find the total amount of material caught in the pans.
- (e) Divide the amount caught in each pan by the total amount. This is the percentage caught in each pan.
- (f) The distribution ratio should be approximately equal to that shown graphically in Figure 11, and by percentage in Table 3, with the shaded area of the table the most important. The unshaded area of the pattern receives negligible product distribution.

NOTE: The distribution pattern shown in Figure 12 and Table 3 represents the ideal pattern, which may not be reproducible in the field.



Operator Manual

Pan number, from left	1	2	3	4	5	center 6	7	8	9	10	11
Material percentage	*	7	9	12	14	16	14	12	9	7	*
*Amount Not Significant											

Table 3. Material Distribution Ratio by Percentage

- (g) To adjust the distribution pattern for the right side, loosen the locking screw on the third-hole remote adjustment lever. Move the lever as necessary to increase or decrease the opening in the adjustment hole. Reset the memory lock.
 - (h) Repeat the passes over the pans and measure the material deposited in the pans. Readjust the openings as necessary until the distribution pattern meets the requirements.
 - (i) Record each opening setting for future recalibration.
- (7) Determine the rate lever setting for each product that will be used. The machine is designed to apply fertilizer evenly by overlapping 50 percent of the last pass. Most fertilizer products spread 14 foot wide. One half of 14 feet (or 7 feet) is the effective material spread width, and used as the basis for calibration.
- (a) Measure a distance of 143 feet (44 meters) over turf. This will provide a spread area of approximately 1,000 ft² (93 m²). The effective material spread width is 7 feet; therefore, 7 x 143 = 1,001 ft² (93 m²).
 - (b) With the machine in neutral (and the hopper closed), run the engine at full throttle. Check the tachometer to make sure the engine is running at 3450 rpm. Once we know that the engine is operating at the correct speed, we can be sure that you'll be traveling at the right speed, as well.
 - (c) With the machine traveling in DRIVE at full throttle, use a stop watch or wrist watch to measure and record the time required to travel the 143 foot (44 meter) turf course. The normal time is approximately 20 seconds.
 - (d) With the machine operating in LOW at full throttle, record the time required to cover the 143 foot (44 meter) turf course. The normal time is approximately 28 seconds.
 - (e) Place the spreader-sprayer over a paved surface and place enough material to cover 1,000 ft² (93 m²) in the hopper. This must be calculated for each specific product. The spreader-sprayer may remain stationary on the hard surface for the remainder of the calibration to make collection and reuse of the material easier.

CALIBRATION AND ADJUSTMENT



Operator Manual

- (f) In neutral, with the engine at full throttle, spread the product, but do not record the first time. The first time required to spread the product is not an accurate measure because some of the product always remains in the hopper.
 - (g) Leave the product that did not spread in the hopper and add enough additional material for 1000 ft² (93 m²) of coverage to the hopper.
 - (h) Spread the product. Measure and record the time required to discharge the product.
 - (i) If the time to spread the product differs from the time measured in step (b), above, adjust the rate lever setting. Moving the rate lever to the right will decrease the time required to spread the product. Moving the rate lever to the left will increase the time required to spread the product.
 - (j) If the rate lever required adjustment, add enough additional material for 1000 ft² of coverage to the hopper. Measure and record the time required to spread the product.
 - (k) If necessary, adjust the rate lever setting and repeat the spread time test until the time to spread product for 1000 ft² (93 m²) meets the 143 foot (44 meter) travel time. Recheck the center hole setting with the gage. If it is more than 10 percent different from the original #13 setting, repeat step c(6).
 - (l) Using the calibration gage, check and record the center hole and third-hole settings for future reference. Record the rate lever setting for future reference. The calibration gauge and rate lever settings will not match.
 - (m) To calibrate the spreader for LOW gear, set the rate lever at a lower number and spread enough material to cover 1000 ft² (93 m²). Adjust and test the rate lever setting until the spread time meets the time measured in step (c), above. Recheck the center hole setting with the gage. If it is more than 10 percent different from the original #13 setting, repeat step c(6).
 - (n) Using the calibration gauge, check and record the center hole and third-hole settings for future reference, and record the rate lever setting for future reference.
- (8) Whenever you change products or rates of application and at one-month intervals, or more frequently during heavy use, verify that the distribution pattern and calibration are still valid. Adjust as necessary.

2. Sprayer Calibration and Adjustment

The spray pattern and spray rate are controlled by the engine speed and pump pressure, and the nozzle orifice. These are constants that do not change unless the machine or a component is not functioning correctly or is misaligned. Check sprayer calibration as follows:

CALIBRATION AND ADJUSTMENT



Operator Manual

- a. Fill the spray tank with water. With the machine in neutral, run the engine at full throttle. Check the tachometer to make sure the engine is running at 3450 rpm.
- b. Set the spray control valve for the nozzle to be checked to the ON position.
- c. Place a catch receptacle in position to catch the entire spray pattern from the nozzle to be checked. Pull the spray lever to begin spraying. Spray for one minute, collecting the nozzle output.
- d. Measure the collected water.
 - (1) Output from the high gear broadcast nozzle (TF-VS5) must be 90 ± 9 ounces (2.7 ± 0.27 liters).
 - (2) Output from the low gear broadcast nozzle (TF-VS3) must be 66 ± 7 ounces (2 ± 0.2 liters).
 - (3) Output from the high gear trim nozzle (ULD120-03) must be 39 ± 4 ounces (1.2 ± 0.12 liters).
 - (4) Output from the low gear trim nozzle (ULD120-02) must be 28 ± 3 ounces (828 ± 83 milliliters).
- e. If the output from a nozzle is significantly outside the limits, refer to Section 4, FAULT ISOLATION.
- f. Adjust the broadcast spray pattern as follows:
 - (1) Rotate the nozzles in the nozzle caps so that the spray pattern is centered forward.
 - (2) Rotate the nozzle body on the pipe nipple so that the spray pattern is slightly below parallel to the ground.
 - (3) Adjust the spray nozzle body so that the pattern width, measured from outermost droplets to outermost droplets, is 11 feet (3.4 meters). Increase the pattern width by raising the nozzle level. Decrease the pattern width by lowering the nozzle level.
- g. Adjust the trim spray pattern as follows:
 - (1) Rotate the nozzles in the nozzle caps so that the spray pattern is centered forward.
 - (2) Rotate the nozzle body on the pipe nipple so that the spray pattern is confined to the width of the spreader-sprayer (three feet, or 0.9 meter).
 - (3) Adjust the spray nozzle body so that the pattern width, measured from outermost droplets to outermost droplets, is three feet (0.9 meter). Increase the pattern width by raising the nozzle level. Decrease the pattern width by lowering the nozzle level.

CALIBRATION AND ADJUSTMENT



Operator Manual

- h. At one-month intervals, or more frequently during heavy use, verify that the spray rates are still valid. Check and adjust the spray pattern whenever necessary. If the spray rate is not within limits, refer to Section 4, FAULT ISOLATION.



THIS PAGE INTENTIONALLY LEFT BLANK



Operator Manual

FAULT ISOLATION

1. Fault Isolation

The failure modes covered in this section are:

- Spreader-sprayer does not start
- Poor spread pattern
- Spreader-sprayer does not spread
- Low spray flow
- High spray flow
- Poor spray pattern
- Spreader-sprayer does not spray

Before beginning the fault isolation procedures, check the spreader sprayer for obvious evidence of damage or failure. This includes physical damage, missing or loose parts, and evidence of failure, such as unusual noises. Do not attempt to operate the spreader-sprayer if there is evidence of failure until the machine has been repaired.

Refer to Table 4 through Table 8 for the fault isolation procedures.

Failure Mode	Check	Corrective Action
Spreader-sprayer does not start.	Check the spreader-sprayer fuel system. If the fuel system is not providing fuel flow to the engine: Check for fuel in the fuel tank. Make sure the fuel shutoff valves are open. Check for a clogged fuel line. Check for contamination in the fuel tank.	If necessary, add fuel to the fuel tank. If the fuel system is not set for operation, set the fuel system to the ON configuration. If the fuel system is contaminated, clean the fuel system.
	Check the choke setting.	If the fuel system has fuel present and the choke is properly set, refer to the engine manual for further fault isolation.
Spreader-sprayer does not start.	Check shift lever setting. Shift lever must be set in neutral. Check the kill switch setting.	If the lever is not set in neutral, move the shift lever to the neutral position. If the starter switch is OFF, set it to ON If the engine does not start, refer to the engine manual.

Table 4. Spreader-Sprayer Does Not Start



Operator Manual

Failure Mode	Check	Corrective Action
<p>Spreader output provides an uneven pattern.</p>	<p>Check for blockage of the spreader holes.</p>	<p>Move the rate adjustment lever to the highest setting, and with the engine at 3450 rpm, momentarily open the shutoff plate to discharge any clumps of material that may have blocked a discharge hole. Return the rate lever to the calibrated setting and check the pattern. If the pattern is still uneven, remove the material from the hopper and clean the holes.</p>
	<p>If hopper opening changes, check for proper bolt tension on the hopper open/close rod and lever under the spray tank.</p>	<p>Tighten the bolt to compress the nylon washers that keep the open/close plate from vibrating closed. The tension needs to be very tight because this is the only point that holds the plate in place. Periodically re-adjust the tension as needed.</p>
	<p>Check the pattern adjustment hole for the area of the pattern that is not correct.</p>	<p>Refer to the spreader adjustment procedure and the setting numbers recorded at prior spreader adjustments. Set the 3rd spreader pattern hole to the proper number and verify the pattern. Repeat and modify the adjustment as necessary.</p>
	<p>Inspect the impeller for worn or clogged blades.</p>	<p>Clean or replace the impeller.</p>

Table 5. Incorrect Spread Pattern



Operator Manual

Failure Mode	Check	Corrective Action
Spreader does not operate when the operator lever is pushed to the OPEN position.	Check for impeller rotation. If the impeller is not rotating, check the following components: Check the impeller shaft. Make sure the impeller shaft has not separated from the impeller and that the shaft assembly block is tight.	If the impeller and impeller shaft have separated, refer to the Maintenance and Repair manual for the repair procedure.
	Check the impeller belt and the drive pulley. Make sure the belt is correctly adjusted.	If the impeller belt is not adjusted so that the drive pulley is driving the belt, refer to the Maintenance and Repair manual for the repair procedure.
	If the impeller pulley and drive belt are correctly adjusted but the drive pulley and belt are not turning, check for rotation from the jackshaft to the engine drive pulley.	If the jackshaft is not rotating, refer to the Maintenance and Repair manual for the repair procedure.
	Check the operator lever adjustment. The operator lever must open the discharge holes.	If the operator lever does not open the discharge holes, adjust the operator lever according to the Maintenance and Repair manual.
	Check the discharge holes. If the operator lever exposes the discharge holes, the holes are clogged with foreign material or caked material.	Empty the hopper and clean the discharge holes. If you use water, use low-pressure shop air to completely dry the hopper before reloading.

Table 6. Spreader Does Not Operate



Operator Manual

Failure Mode	Check	Corrective Action
Spray pattern not correctly aimed.	Check the spray nozzle positioning.	Correctly position the spray nozzle according to paragraph 9, Sprayer Calibration and Adjustment.
Spray flow is low at 3450 rpm. This can decrease the width of the spray pattern.	Check the spray tank relief valve. The relief valve must provide a pressure of 15 psi (103 kPa).	If the pressure is low, clean, adjust, or replace the relief valve according to the Maintenance and Repair manual.
	Check the spray nozzle and strainer for an obstruction.	Clean, adjust, or replace the spray nozzle and strainer according to the Maintenance and Repair manual.
Spray flow is high at 3450 rpm. This can increase the width of the spray pattern.	Check the spray tank relief valve. The relief valve must provide a pressure of 15 psi (103 kPa).	If the pressure is high, clean, adjust, or replace the relief valve according to the Maintenance and Repair manual.
	Check the spray nozzle for damage.	If the spray nozzle is damaged, replace the spray nozzle according to the Maintenance and Repair manual.

Table 7. Incorrect Spray Pattern



Operator Manual

Failure Mode	Check	Corrective Action
Sprayer has no output.	Open the drain valve and increase the engine speed to 3450 rpm. If the pump is primed, there will be flow.	If there is no flow, allow the air trapped in the system to escape. Close the valve when pressure and flow begin.
	Check the relief valve.	If there is no flow into the tank through the relief valve, the relief valve may be obstructed or has failed. Clean, repair, or replace the relief valve according to the Maintenance and Repair manual.
	If there is flow into the tank through the relief valve, check the pump control valve and nozzles.	Open the valve by manually operating the lever. Test the valve. Then, remove one of the nozzles and strainers and test the valve. Clean or replace the nozzles or control valve or the cable.
	If there is flow into the tank from the relief valve, disconnect the line from the relief valve to the control valve.	If there is no flow from the relief valve, the valve has failed in the bypass position. Repair or replace the relief valve according to the Maintenance and Repair manual.
	If there is no flow into the tank from the relief valve, check the suction strainer.	Remove and clean the strainer.
	If there is flow from the relief valve output, disconnect the line from the relief valve to the control valve at the control valve.	If there is no flow at the control valve, the line is obstructed or damaged. Clean or replace the line according to the Maintenance and Repair manual.
	If there is flow from the relief valve to the control valve, the control valve is obstructed or failed.	Check, clean, repair, or replace the control valve according to the instructions in the Maintenance and Repair manual.

Table 8. Sprayer Does Not Operate (sheet 1 of 2)



Operator Manual

Failure Mode	Check	Corrective Action
<p>Sprayer has no output (continued).</p>	<p>Check the pump.</p>	<p>Verify that the pump shaft is turning when the engine speed is increased to 3450 rpm. If necessary, tighten the setscrew on the pulley.</p> <p>If the pump shaft is turning, loosen the suction fitting and check for flow.</p> <p>If there is suction flow, tighten the suction fitting and loosen the discharge fitting. Check for high-pressure flow. If there is flow and pressure, tighten the discharge fitting.</p> <p>If there is no flow, replace the pump.</p>

Table 8. Sprayer Does Not Operate (sheet 2 of 2)



Operator Manual

MAINTENANCE

1. Maintenance

Keeping the Magnum A1A spreader-sprayer operating reliably requires attention to maintenance. Using the Daily Maintenance and Safety Checklist as a maintenance guide provided in this manual, and the periodic maintenance tables provided in the Maintenance and Repair Manual prevents damage to your machine, and prevents malfunctions that could occur if the maintenance was not performed. It is also essential for safe operation of the machine.

WARNING: TO AVOID PERSONAL INJURY, PERFORM MACHINE MAINTENANCE WITH THE ENGINE OFF. IF THE ENGINE HAS BEEN OPERATING, MAKE SURE THE ENGINE HAS COOLED BEFORE PERFORMING ANY MAINTENANCE ON THE ENGINE.

The daily maintenance and periodic maintenance can be performed either before using the machine, or at the completion of a day's use.

When you perform the daily maintenance, date the maintenance log, initial the log, and check off each procedure. Pay particular attention to the following items:

- a. Check the machine hour meter. Perform the scheduled maintenance required by the operation time (refer to the Maintenance and Repair manual).
- b. Visually check the hopper discharge holes to make sure they are clear. Check the slides and the spinner mechanism to make sure they are not obstructed.
- c. With the spreader-sprayer on a level surface, check the engine oil level. Add oil if necessary. Refer to Table 1 for engine and gearbox oil capacity and type
- d. After each 25 hours of operating time, the hour meter will flash LUBE for one hour, indicating that the engine and transmission oil may be scheduled for changing. At the end of an hour of operation, the hour meter will cease flashing LUBE until the next 25 operating hours have elapsed. It is not necessary to interrupt the use of the machine to immediately change the oil, but it is necessary to change the oil either at the end of the day's use or before the start of the next day's use. Refer to the Maintenance and Repair manual for the engine and transmission oil change procedures and the 25-hour interval maintenance checklists.
- e. Spray the moving parts except for the drive belt and drive pulleys with a light coat of WD-40, or equivalent. Pay particular attention to carburetor linkage, throttle cable and lever, and throttle return spring.



Operator Manual

DAILY MAINTENANCE AND SAFETY CHECKLIST

Ride-On Magnum A1A Serial No. _____

DATE	INITIALS	RECORD MACHINE HOURS	CHECK OIL	CLEAN DEBRIS FROM ENGINE, MUFFLER	LOW PRESSURE WASH MACHINE AND HOPPER	AIR BLOW MACHINE AND HOPPER DRY	CHECK AND TIGHTEN FASTENERS	CHECK/RECORD IDLE RPM (1400 +200/-150 RPM)	CHECK/RECORD RUN RPM (3450 RPM)	CHECK CENTER PATTERN SETTING	CHECK THIRD HOLE PATTERN SETTING	SPRAY WD-40, ALL MOVING PARTS



Operator Manual

WARRANTY

Perma Green Supreme, Inc. hereby warrants to the original purchaser that the Magnum A1A manufactured by Perma Green Supreme, Inc. will be free from defects in material and workmanship for a period of one year from the date of delivery or the first 500 operating hours, whichever comes first, except as noted below.

PROTECTION PLAN

The Company will provide replacement parts for parts found defective. Such replacement parts will be free of charge to the purchaser for one year from the date of delivery or the first 500 operating hours, whichever comes first.

This Warranty is subject to the following exceptions and limitations:

PURCHASER RESPONSIBILITIES:

Timely maintenance, adjustments, and record keeping per the Warranty Maintenance Log and Engine Manual.

Prior notification of Perma Green Supreme, Inc. of the need for Warranty Service.

Transportation to and from the place of warranty repair.

Return of a Warranty Claim Form, the parts in question, and copies of Warranty Maintenance Logs, within 30 days of warranty repair, to Perma Green Supreme, Inc. for examination and warranty approval as described in Warranty Instructions/Policy.

EXCLUSIONS:

No warranty is extended to any equipment or parts that have been altered, misused, improperly adjusted, neglected, or damaged by accident, disasters, or normal wear and tear.

No warranty is extended on any parts that are not manufactured by Perma Green Supreme, Inc., such as the engine, which is covered by the manufacturer's warranty.

This Warranty does not cover replacement of expendable maintenance items made in connection with the required maintenance services after the item's first scheduled check and replacement as listed in the maintenance manual, such as: spark plugs, belts and filters.

Perma Green Supreme, Inc. reserves the right to incorporate any changes in design into its products without obligation to make such changes on products previously manufactured.

LIMITATION OF REMEDIES

UNDER NO CIRCUMSTANCES, EXCEPT TO THE EXTENT PRESCRIBED BY APPLICABLE LAW, SHALL PERMA GREEN SUPREME, INC. BE LIABLE FOR ANY LOSS OR DAMAGE, DIRECT OR INDIRECT, SPECIAL OR CONSEQUENTIAL ARISING OUT OF THE USE OF OR INABILITY TO USE THIS EQUIPMENT, INCLUDING BUT NOT LIMITED TO ANY CLAIM FOR LOSS OF PROFITS, LOSS OF SAVINGS OR REVENUE, LOSS OF USE OF EQUIPMENT OR ANY ASSOCIATED EQUIPMENT, FACILITIES OR SERVICE, DOWNTIME, THE CLAIMS OR COSTS OF THIRD PARTIES INCLUDING CUSTOMERS, AND INJURY TO PROPERTY. Some states do not allow limitations on how long an implied warranty lasts or the exclusion or limitation of incidental or consequential damages, so the limitations or exclusions may not apply to you. This warranty gives you specific legal rights, and you may also have rights that vary from state to state.



Operator Manual

THIS PAGE INTENTIONALLY LEFT BLANK